

# Chapter 6

## The image of automobile safety

Taro Sekine

Associate Professor, Department of Mechanical Engineering, College of Science and Technology, Nihon University

### 6.1 Changes in traffic accident statistics and safety measures

Chapter 6 considers the issue of automobiles in road traffic, reflecting on the history of safety improvement technology initiatives and clarifying the image of safety that serves as the end goal. To begin, we reexamine the traffic accident statistics, which form the background for this issue.

Figure 1<sup>1)</sup> shows annual changes in the number of traffic accidents in Japan. Looking at the long-term trend of traffic fatalities from 1951 to 2013, there are two noticeable peaks. These increases and decreases are closely associated with the growth and social situation of the traffic society. The rapid

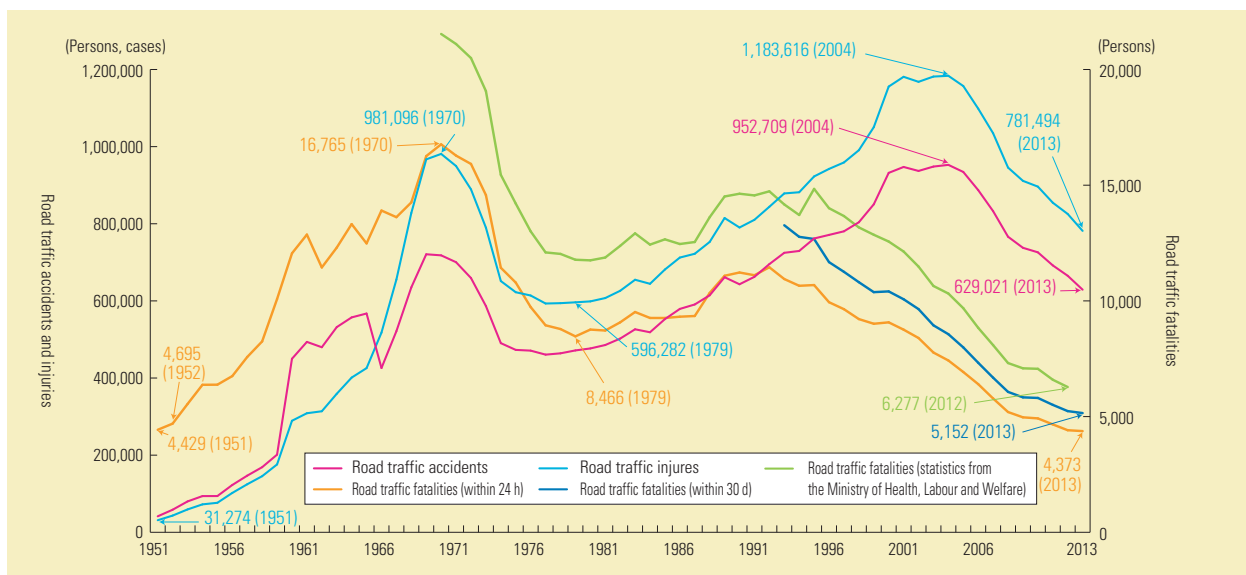

Note 1: Based on documents issued by the National Police Agency.

Note 2: Accidents involving property damage are not included in the number of cases after 1966. Okinawa Prefecture was not included in the survey until 1971.

Note 3: According to Article 2, Paragraph 1, Item 1 of the Road Traffic Act, "24-h fatalities" are persons who died within 24 h of a road traffic accident such as those involving automobiles, trains, or other vehicles.

Note 4: "Thirty-day fatalities" are persons who died within 30 days of a traffic accident (inclusive of 24-h fatalities).

Note 5: Fatalities in the statistics of the Ministry of Health, Labour and Welfare were provided by the National Police Agency based on the vital statistics collected by the Ministry of Health, Labour and Welfare. The number represents fatalities due to traffic accidents in the reference year and excludes persons who died after more than 1 year or due to accident-related aftereffects. Before 1995, all automobile accidents are included, but the number for years later than 1995 is calculated by subtracting the number of fatalities due to non-road traffic accidents from the number of fatalities due to traffic accidents on land.

Figure 1. Number of traffic accidents, fatalities, and injuries on Japanese roads<sup>1)</sup>

increase that begins in the 1950's and culminates in a peak of 16,765 deaths (within 24 hours of accident) and 981,096 injuries in 1970 is what is informally called "Traffic War I." Factor analysis of the situation indicates that it is the result of insufficient road maintenance, improvements, and traffic safety facilities for the increased traffic loads caused by a rapid increase in private four-wheeled automobile ownership. Other contributing factors include the change in consciousness of traffic participants not keeping up with the rapid changes in the traffic society as well as insufficient technologies for ensuring the safety of vehicles.

For this reason, the Traffic Safety Policies Basic Act was enacted in 1970 to promote traffic safety measures throughout the country. To account for the slow pace of changes in consciousness by traffic participants, countermeasures at the time promoted vehicle–pedestrian separation, such as through the creation of footbridges in addition to crosswalks and traffic signals, and through creation of guardrails (see Reference 2 for details of traffic facilities at the time). Automobile safety features such as those in the Experimental Safety Vehicle, as will be discussed later, began to be considered, and beginning in April 1969, driver's seat safety belts became required in all domestically manufactured passenger vehicles. The requirement for safety belts would later be extended to passenger seats, and then to rear seats. As a result of these measures, the number of fatalities trended downward until 1979 from its 1970 peak.

Following that, further increases in the number of privately owned automobiles and of driver's license holders resulted in a corresponding increase in automobile-kilometers travelled, creating a second upward trend in traffic accidents. There was a particularly noticeable increase in automobile-kilometers travelled over the five-year period of economic prosperity beginning in 1986. Figure 2 shows the results, with the number of passenger vehicle accident fatalities<sup>1)</sup> once again surpassing the 10,000

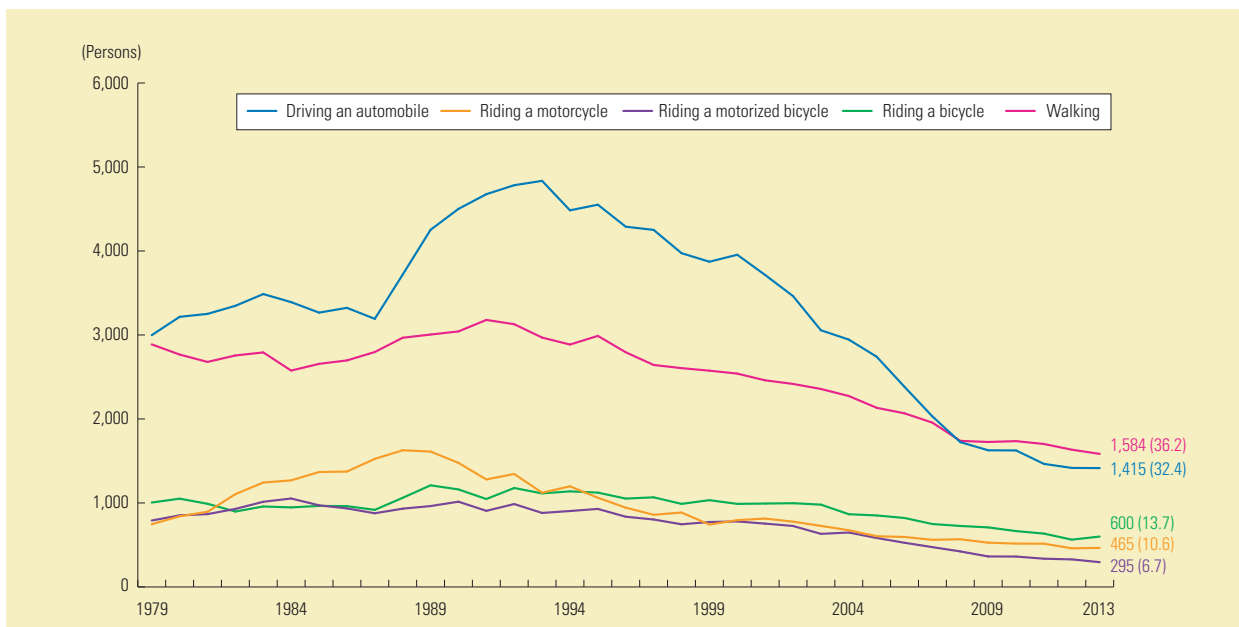

Note 1: Based on documents provided by the National Police Agency ("Other" is not shown).

Note 2: Number in parentheses indicates the percentage of all injuries for that mode of transportation.

**Figure 2. Changes in the number of traffic accident fatalities by mode of transport<sup>1)</sup>**

(within 24 hours) mark. This period is referred to as “Traffic War II.”

To address this and reduce the number of passenger vehicle fatalities, automobile safety measures such as anti-lock braking systems and airbags were promoted and became more common (Fig. 3<sup>3</sup>). In 1992, driver and passenger seatbelt usage in general road driving was made mandatory, and increased seatbelt usage rates along with improvements to emergency care systems had the effect of decreasing accident fatality rates (within 24 hours) following the peak in 1993 (Fig. 1<sup>1</sup>). Note, however, that in contrast to the situation in the 1970s, the number of traffic accidents and injuries continued to increase for 10 years after the peak in 1993. This is because improvements to automobile safety features and emergency care systems lowered the fatality rates of serious accidents, meaning that those who would have died in the 1970s setting were instead only injured.

Beginning in 2004, there has been a further reduction in the number of traffic fatalities alongside a reduced number of traffic accidents, due to a number of factors including the dissemination of vehicle safety technologies such as collision mitigation braking systems and skid prevention devices, promotion of automotive development through public evaluation of collision safety performance by car assessment programs, increased penalties for drunken driving, increased rates of seatbelt usage, improvements in driver courtesy such as reduced speeding rates, and a reduced number of automobile-kilometers driven. As of 2013, the number of annual traffic accidents is holding steady at approximately 600,000.

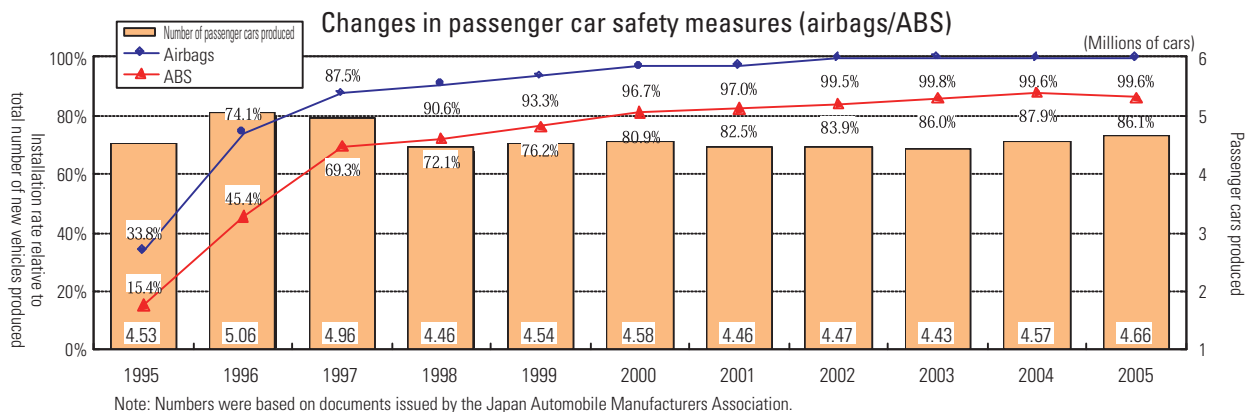

**Figure 3. Changes in passenger car safety measures (airbags/ABS)<sup>3</sup>**

The increasingly aging society in Japan of recent years has resulted in changes in traffic accident trends. Since 2008 in particular, there has been a reversal in the number of pedestrian and automobile passenger fatalities (Fig. 2). Examining the number of traffic accident fatality rates by conditions and age (Fig. 4<sup>1</sup>), one can see a remarkable increase in the ratio of deaths of age 65 and older pedestrians in accidents involving automobiles. Older people now have higher driver’s license possession rates, resulting in a trend of increased traffic fatalities involving elderly (age 75 or older) drivers.<sup>4</sup>

Given these trends in traffic accidents of recent years, the 9th Traffic Safety Basic Plan of the Cabinet Office places a high emphasis on preserving the safety of pedestrians and cyclists along residential roads, the primary living environment for the elderly.<sup>5</sup> Recent automotive safety features to accommodate these changes include alterations to vehicle nose shapes and pop-up hood systems as well as other

vehicle body structural modifications for the reduction of injury in the event of a pedestrian collision. Low-speed collision avoidance braking systems that can reduce the severity of impact with pedestrians and cyclists are also increasingly being deployed.

Automotive safety technology development is thus proceeding based on traffic accident factor analysis, and development and deployment

of these technologies are helping to reduce the number of traffic accidents. In the next section we will take a closer look at trends in safety technology development over each era.

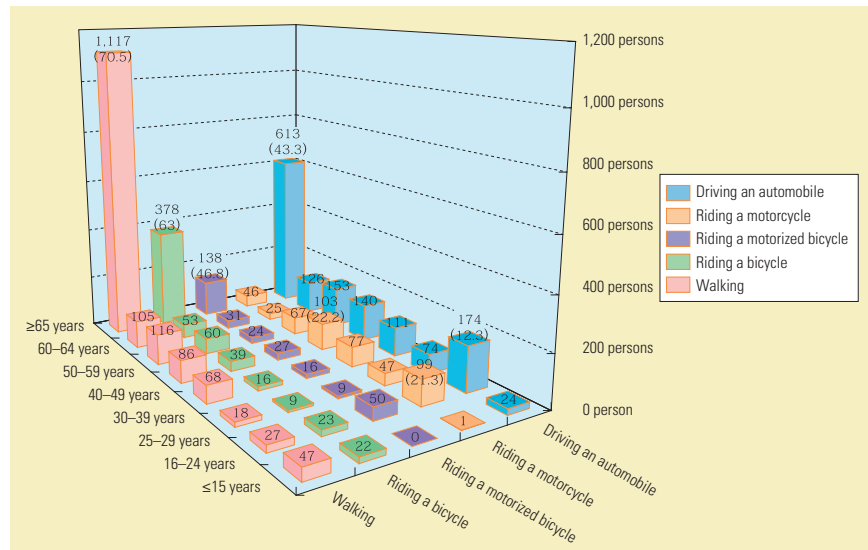

Figure 4. Number of traffic fatalities by mode of transportation and age group<sup>1)</sup>

## 6.2 History and trends of automobile safety technology development

### 6.2.1 The dawn of safety measures: The ESV

As discussed above, the 1960s was an era of rapid motorization, not only in Japan but also in many countries throughout the world, and around this time traffic safety attracted increased attention. To improve the state of traffic safety, in 1970 the National Highway Traffic Safety Administration of the U.S. Department of Transportation proposed development of the ESV, a test vehicle incorporating state-of-the-art car safety technology. With the goal of reducing vehicle occupant fatalities, the ESV would target technological advances for protecting occupants and aiding danger avoidance by drivers. In the U.S. at the time, 60% of traffic fatalities were of passengers, so the U.S. plan may have been aimed at reducing these numbers through passenger protection in the event of collisions.<sup>6)</sup>

In November 1970 the governments of the United States, Japan, and then West Germany exchanged an agreement to implement the plan, bringing Japan into the project. At the time, the U.S. planned for standards based on a vehicle weight of approximately 1800 kg. In Japan, however, a special committee in 1971 considered and determined separate specifications for small vehicles—a 1150-kg four-seat vehicle and a lighter 900-kg two-seat vehicle—and put out a call for developers. The Japanese standards aimed to include a survival space in which occupants could expect to survive a head-on or rear-end collision at speeds of up to 80 km/h, and included other preventative safety features for accident avoidance. Another feature of the Japanese standards is that they called for adherence to both the Japanese Road Trucking Vehicles Act and to the U.S. Federal Motor Vehicle Safety Standards.

The following presents specific examples of some of the safety technologies developed as part of the

ESV program.

One such advance was improvements to vehicle construction designed for absorbing energy in frontal impacts of up to 80 km/h. These include the adoption of impact energy-absorbing frames and pillars and side beams designed to preserve a survival space for passengers.<sup>7)</sup> To aid in calculating these new frame designs, engineers in the U.S. used NASTRAN, a finite element method application developed as part of NASA's Apollo Program and released free of charge thereafter for private technology transfer. It is notable that the techniques used for body rigidity and similar calculations today got their start in this early application for automobiles.

Another advance resulting from the ESV program was airbags. There had been previous proposals for collision detection technologies coupled with safety cushioning, but none had yet been realized. At the same time as the ESV program, proposals for the mandatory use of seatbelts were being debated, which increased demands for a passive restraint system that could mitigate the force of collisions without the use of seatbelts. This provided a reason for airbags to be considered as part of the ESV program. This led to General Motors bringing to market the world's first mass-produced automobile equipped with an airbag system.

There were also advances toward better accident avoidance, such as an anti-skid braking system (now called anti-lock braking), and sideslip-limiting features (now called electronic stability control). These two systems together significantly improve vehicle stability when braking.

Participating companies developed and implemented performance evaluations on several test vehicles through the ESV program, which was generally complete by the time of its 5th International Conference in 1974. The program was successful in its goals of actually producing a test vehicle that included the state-of-the-art technology of the time, but these efforts were undertaken without consideration of

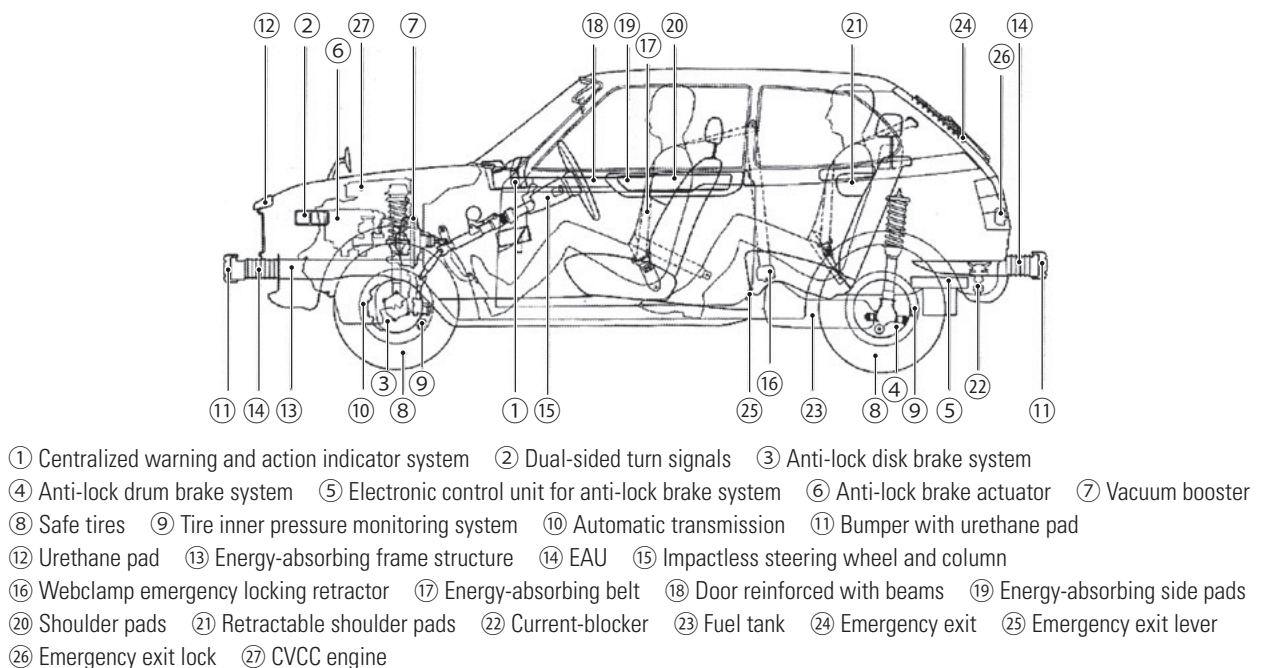

**Figure 5. Experimental safety vehicle (structural diagram of the Honda ESV)<sup>9)</sup>**

manufacturability or costs. The Research Safety Vehicle Program based on consumption trends and mass productivity took over where the ESV left off, but now focuses its consideration on developing issues such as energy shortage and environmental concerns.<sup>8)</sup> The numerous safety features that began as part of the ESV program and are now implemented in actual production vehicles (Fig. 5<sup>9)</sup>) are a testament to the significant role it played in the development of new safety-related technologies.

### 6.2.2 The Advanced Safety Vehicle

Figure 6 shows trends from 1970–1990 for Japanese, U.S., and European projects related to intelligent transport systems (ITS). From this figure, one can see that there were various Ministry-sponsored projects now linked to current ITS that began in the late-1980s Japan, encompassing the Traffic War II period.

Among these projects, the one relating to vehicles is the Advanced Safety Vehicle (ASV) program, which began from the Japanese Land, Infrastructure and Transportation Ministry. The project has been ongoing since 1991, and as of 2014 is now in its fifth five-year plan. The project is guided by a review committee that includes representatives from among academic experts, affiliated organizations, relevant ministries and agencies, and fourteen automobile and motorcycle manufacturers. Table 1 shows an overview of the ASV program’s promotional plan for each period.

The ASV program aims at preventing accidents and reducing damage due to collisions through implementation of electronic control technologies that were rapidly developing in the 1980s, and furthermore by establishing the technological foundation for vehicle-side ITS features. ASV vehicles therefore feature a variety of sensors (Fig. 7) and control mechanisms.

The program’s first period (1991–1995) was largely focused on technological considerations for

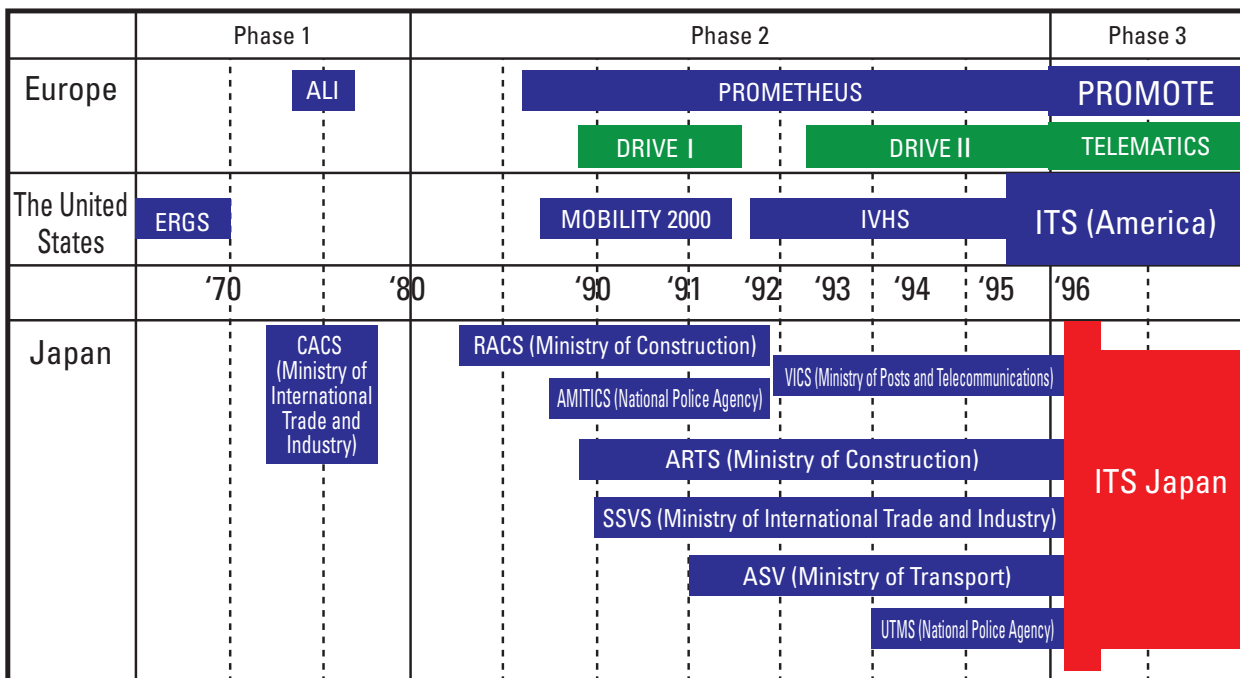
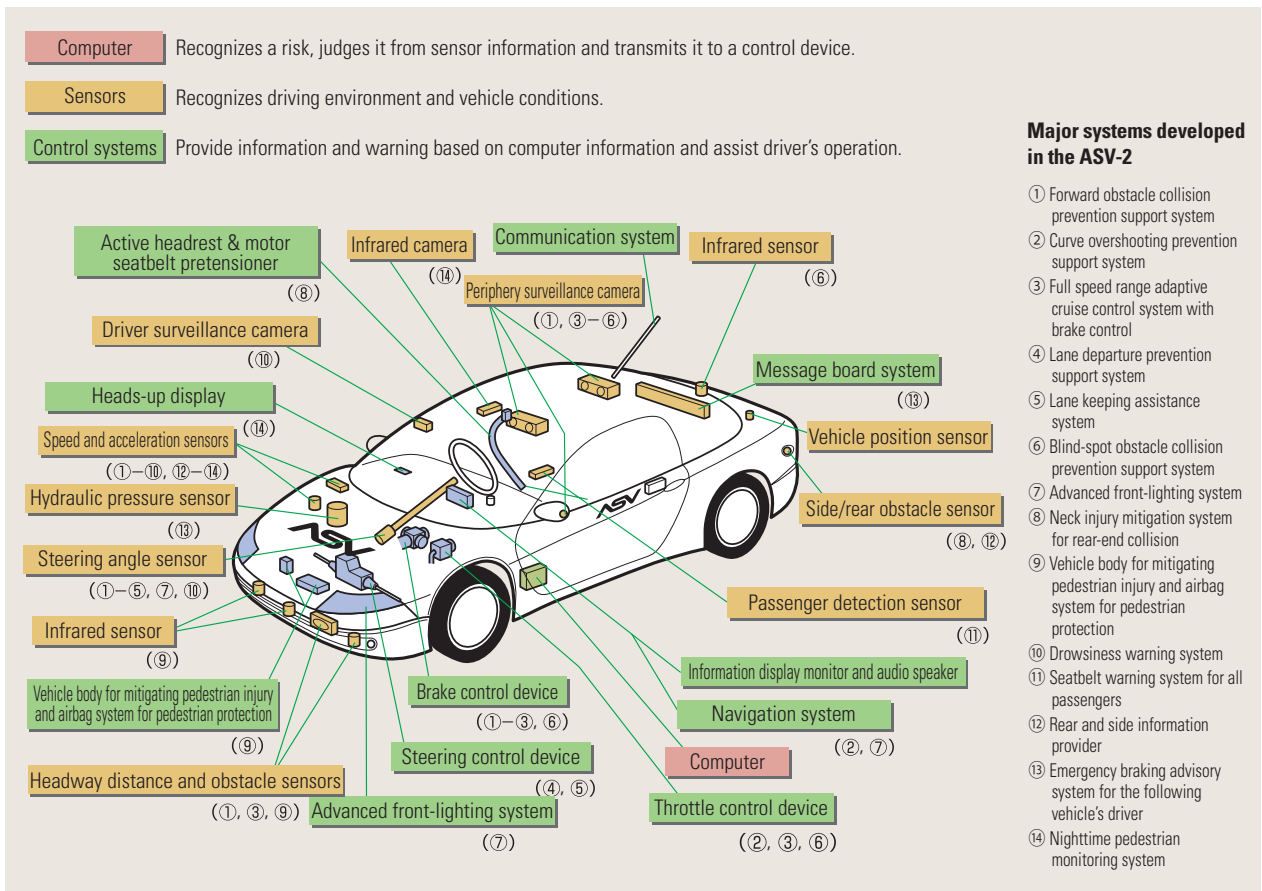

Figure 6. Early phases of the ITS-related projects (organization names are for the indicated year)

**Table 1. Outline of timeline for ASV promotion<sup>10)</sup>**

Phase 1	Phase 2	Phase 3	Phase 4	Phase 5
1991–1995	1996–2000	2001–2005	2006–2010	2011–2015
<ul style="list-style-type: none"> <li>• Proving technological feasibility</li> </ul>	<ul style="list-style-type: none"> <li>• Research and development for commercialization</li> </ul>	<ul style="list-style-type: none"> <li>• Investigation for promotion and marketing</li> <li>• Development of additional technologies</li> </ul>	<ul style="list-style-type: none"> <li>• Full-scale marketing</li> <li>• Partial commercialization of the communication-based safety system</li> </ul>	<ul style="list-style-type: none"> <li>• Dramatic advancement</li> </ul>
<ul style="list-style-type: none"> <li>• Single vehicle (self-sensing type)</li> </ul>	<ul style="list-style-type: none"> <li>• Single vehicle (self-sensing type)</li> <li>• Vehicle-infrastructure cooperation</li> </ul>	<ul style="list-style-type: none"> <li>• Single vehicle (self-sensing type)</li> <li>• Vehicle-infrastructure cooperation</li> </ul>	<ul style="list-style-type: none"> <li>• Single vehicle (self-sensing type)</li> <li>• Links with other vehicles</li> <li>• Vehicle-infrastructure cooperation</li> </ul>	<ul style="list-style-type: none"> <li>• Dramatic advancement in commercialized ASV technology</li> <li>• Next-generation communication-based driving</li> <li>• Development and marketing of the support system</li> </ul>



**Figure 7. Schematic of ASV<sup>11)</sup>**

passenger cars, but starting with the second period (1996–2000) extended to large trucks and motorcycles. Another characteristic of the second period is that it marks the point when international ITS research began to take off. In the ministry publication *Comprehensive Plan for Intelligent Transport Systems*, published in July 1996, the ASV was promoted as a part of “support for safe driving.” Cooperation between the vehicle and the road infrastructure was also considered, and in October 2000 cooperative verification experiments were performed at the Ministry of Land, Infrastructure and Transport’s Public Works’ Research Institute (formerly the Ministry of Construction’s Public Works Research Institute) in Tsukuba, Ibaraki Prefecture. These experiments aimed to test driver acceptance and the appropriateness

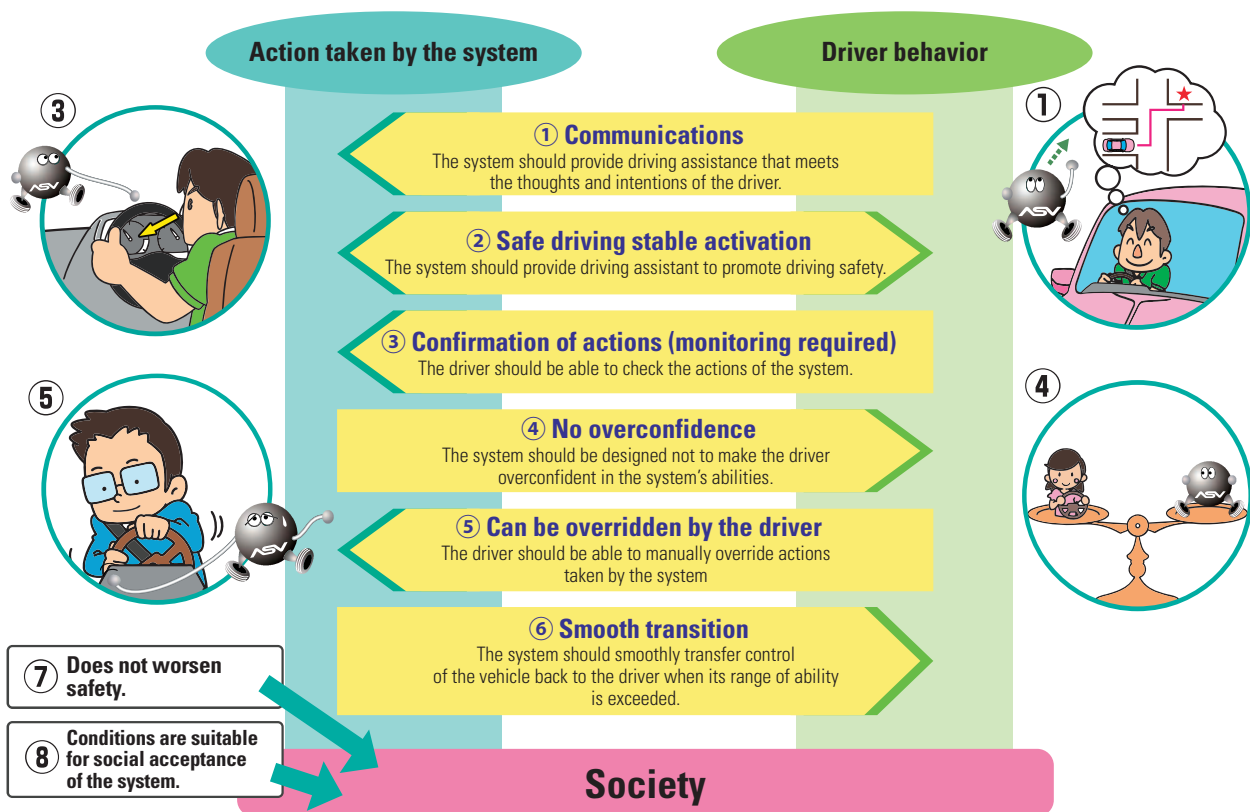

Figure 8. Flow of driving assistance<sup>12)</sup>

of road infrastructure for seven services for integration with an advanced cruise-assist highway system: forward obstacle collision prevention, curve approach risk prevention, lane departure prevention, intersection collision prevention, right turn collision prevention, crosswalk pedestrian collision prevention, and vehicle spacing maintenance through use of road surface information.

The third period (2001–2005) was largely concerned with advancing promotion of the ASV. At this time, the “Design principles of ASV” that were developed in the second period were concretely compiled into “concepts for driving assistance” (Fig. 8<sup>12)</sup>). With regards to “retaining driver acceptance,” for example, it is important that the driver be able to confirm system operations. A “principle for driver assistance” clarifies that it is the driver who must be the central component of safe driving, and that ASV technologies are intended only to serve a sideline support role. This principle requires that in actualized devices there must be a driver-operable switch that enables operation of the assistance system, and that even when the system is enabled, it must be possible for the driver to forcefully intervene. To ensure system integrity, this principle for driver assistance will need to be incorporated as part of the legal preparations for actualization of the automatic driving systems that are currently under development.

Basic system designs for driving support systems that incorporate communications were taken up in the fourth period (2006–2010), and are being used in vehicle surroundings recognition support services that use vehicle-to-vehicle communications for accident avoidance, and are expected to reduce the number of accidents at intersections and during turns. Also under consideration are accident prediction applications using accident analysis to monitor driver state in commercial vehicles to prevent the health-



related accidents that are a social problem in the current age.

### 6.2.3 The future of the ITS concept

As described in the previous section, automotive technologies using electronics and communications technologies for reducing accidents and improving safety have an important position in the ITS field. The ITS interim plan (2011–2015) created by ITS Japan in 2011 calls for a next-generation mobility system that integrates traffic networks, energy networks, and communications networks.<sup>13)</sup> Of particular note is that as a result of the 2011 Great East Japan Earthquake, the report specifies the need for construction of an ITS-based information infrastructure that remains usable in times of disaster. Another development is that of systems combining ASV and communications technologies for vehicle-to-vehicle communications through multi-POP routing, for example, to realize information sharing related to other vehicles in the vicinity or road conditions ahead, thus ensuring the safety of entire groups instead of just individual cars. Such advance sharing of information related to potential risks and dangers will likely reduce the number of traffic accidents. The development of new support technologies for pedestrians, cyclists, and new forms of mobility will also help to compensate for the effects of driver inexperience and cognitive decline due to aging, helping to realize a transportation society through which all members can safely move.<sup>14)</sup>

At the 20th ITS International Conference held in Tokyo in 2013, various companies gave demonstrations of their automatic driving systems, indicating that realization of these systems is now well supported at the government level.<sup>15)</sup> A summary roadmap clearly defines the driving support and automated operation systems presented in the previous section regarding ASV (Table 2), and strategies such as unification of autonomous and cooperative systems are listed along with items of emphasis.

**Table 2. Definition of driving safety support and automatic driving systems<sup>15)</sup>**

Category		Overview	Corresponding system	
Information provided type		Warning the driver, etc.	Driving safety support system	
Automated type	Level 1: Single operation	The vehicle performs acceleration, steering, or braking.		
	Level 2: Complex system	The vehicle performs one or two acceleration, steering, and braking operations simultaneously.	Semi-automated driving system	Automated driving system
	Level 3: Advanced system	The vehicle performs all acceleration, steering, and braking operations (emergency response: driver).		
	Level 4: Fully automated driving system	The vehicle (not the driver) performs all acceleration, steering, and braking operations.	Fully automated driving system	

#### References

- 1) Cabinet Office. 2014. *Heisei 26 nenban kotsu anzen hakusho* [White paper on traffic safety in Japan 2014]. Accessed December 10, 2014. [http://www8.cao.go.jp/koutu/taisaku/h26kou\\_haku/zenbun/index.html](http://www8.cao.go.jp/koutu/taisaku/h26kou_haku/zenbun/index.html). (in Japanese)
- 2) Fukuda, Atsushi et al. 2011. “Kotsu senso eno torikumi: tojo koku ni koken shiuru nihon no keiken to chiken” [Managing traffic war: Japan’s experience and knowledge that can contribute to solving traffic issues in developing countries]. *Heisei 22 nendo kenkyu chosa hokokusho* [Research report 2012]. International Association of Traffic and Safety Sciences. (in Japanese)

- 3) The National Police Agency, Traffic Bureau. 2007. *Heisei 18 nen chu no kotsu shibojiko no tokucho oyobi doro kotsuho ihan torishimari jokyo ni tsuite* [Characteristics of fatal traffic accidents and effectiveness of traffic violation control]. (in Japanese)
- 4) Institute for Traffic Accident Research and Data Analysis. 2012. “Kotsu tokei heisei 24 nen ban.” [Statistics for traffic 2012]. Accessed December 10, 2014. <http://www.itarda.or.jp/>. (in Japanese)
- 5) Cabinet Office. 2011. “Dai 9 ji kotsu anzen kihon keikaku.” [Traffic safety basic plan 9]. Accessed December 10, 2014. <http://www8.cao.go.jp/koutu/kihon/keikaku9/>. (in Japanese)
- 6) Okami, Yoshiro. 1976. “Safety and the ESV Program.” *IATSS Review* Vol. 2, No. 2: 132–140. (in Japanese)
- 7) Toyota Motor Corporation. “Toyota jidosha 75 nenshi” [75 years of Toyota]. Accessed December 10, 2014. <http://www.toyota.co.jp/jpn/company/history/75years/text/index.html>. (in Japanese)
- 8) Sano, Shoichi. 1979. “ESV Program and the Perspective of Study on Automobile Safety.” *IATSS Review* Vol. 5, No. 4: 300–305. (in Japanese)
- 9) Society of Automotive Engineers of Japan, ed. 2009. *Jidosha no hyakka jiten* [Encyclopedia of automobiles]. Maruzen Publishing. (in Japanese)
- 10) Ministry of Land, Infrastructure, Transport and Tourism. *ASV suishin keikaku ni tsuite* [About ASV Promotion Program]. Accessed December 10, 2014. <http://www.mlit.go.jp/jidosha/anzen/01asv/aboutasv.html>. (in Japanese)
- 11) Ministry of Land, Infrastructure, Transport and Tourism. 2002. *Dai 3ki ASV suishin keikaku panfuretto* [ASV Promotion Program pamphlet (Third period)]. (in Japanese)
- 12) Ministry of Land, Infrastructure, Transport and Tourism. 2011. *Dai 5ki ASV suishin keikaku panfuretto* [ASV Promotion Program pamphlet (Fifth period)]. (in Japanese)
- 13) ITS Japan. 2011. *ITS Shin chuki keikaku (2011–2015 nen) no sakutei* [Development of a new midterm ITS plan 2011–2015]. Accessed December 10, 2014. [http://www.its-jp.org/katsudou\\_old/katudou170/](http://www.its-jp.org/katsudou_old/katudou170/). (in Japanese)
- 14) ITS Japan. 2013. *ITS niyoru mirai sozo no teigen: daredemo dokodemo kaiteki ni ido dekiru shakai no jitsugen* [Recommendations of the creation of the future by ITS: creating the society that provides everyone with access to any place with comfort]. Accessed December 10, 2014. [http://www.its-jp.org/document/20131017/ITS-future-vision\\_j\\_131010.pdf](http://www.its-jp.org/document/20131017/ITS-future-vision_j_131010.pdf). (in Japanese)
- 15) IT Strategic headquarters. 2014. *Kanmin ITS koso/rodo mappu* [Government and people ITS framework/roadmap]. (in Japanese)

#### Recommended Reading

- 1) Ministry of Land, Infrastructure, Transport and Tourism. “ASV ni kansuru kenkyu seika hokokusho” [Results of research on ASV]. Accessed December 10, 2014. <http://www.mlit.go.jp/jidosha/anzen/01asv/index.html>. (in Japanese)
- 2) Ministry of Land, Infrastructure, Transport and Tourism. 2001. “Senshin anzen jidosha (ASV) suishin keikaku (dai 2 ki) ni kansuru hokokusho” [Report on promotion plan for advanced safety vehicles (2nd stage)]. Accessed December 10, 2014. <http://www.mlit.go.jp/jidosha/anzen/01asv/resource/data/asv2report.pdf>. (in Japanese)
- 3) Ministry of Land, Infrastructure, Transport and Tourism. 2006. “Senshin anzen jidosha (ASV) suishin keikaku hokokusho: dai 3 ki ASV keikaku ni okeru katsudo seika ni tsuite” [Report on the promotion plan for advanced safety vehicles: results of ASV promotion plan (3rd stage)]. Accessed December 10, 2014. <http://www.mlit.go.jp/jidosha/anzen/01asv/resource/data/asv3seikahoukokusyocorrection.pdf>. (in Japanese)
- 4) Ministry of Land, Infrastructure, Transport and Tourism. 2011. “Senshin anzen jidosha (ASV) suishin keikaku hokokusho: dai 4 ki ASV keikaku ni okeru katsudo seika ni tsuite” [Report on the promotion plan for advanced safety vehicles: results of ASV promotion plan (4th stage)]. Accessed December 10, 2014. [http://www.mlit.go.jp/jidosha/anzen/01asv/resource/data/asv4pamphlet\\_seika.pdf](http://www.mlit.go.jp/jidosha/anzen/01asv/resource/data/asv4pamphlet_seika.pdf). (in Japanese)